



Guide technique / Technische Anleitung / Technical Guide

TG-19-C-003-FDE

C

Fait par: pelrom

Date: 04.04.2005

CALIBRE - KALIBER - CALIBRE 2500 C

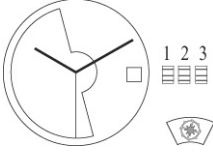
$11\frac{1}{2}'''$ Ø 25,60 mm	
Hauteur sur mouvement Höhe auf Uhrwerk Height on movement	4.10 mm
Réserve de marche / Gangreserve / Power reserve Nombre de rubis / Anzahl Rubine / Number of jewels Fréquence / Frequenz / Frequency Angle de levée / Hebungswinkel der Unruh / Angle of lift	48 h 27 3.5 Hz (25'200 A/h) 38°

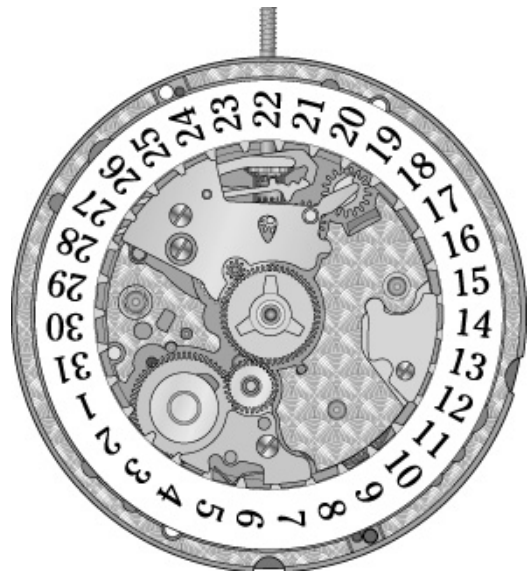
**Echappement Co-Axial****Co-Axial Hemmung****Co-Axial escapement**Français
Deutsch
English

Informations générales – Allgemeine Informationen – General information

Description

Mouvement automatique, échappement Co-Axial, date, certifié COSC, système balancier Omega sans raquette.

Points importants

L'ordre de montage des deux vis du pont d'ancre doit être respecté (voir page 11).

Après le montage, les fonctions de l'échappement doivent être contrôlées précisément avec l'outil correspondant.

Correction de la date

La correction de la date est déconseillée entre 22 h et 02 h.

Pose des aiguilles

Pour la pose des aiguilles, le mouvement doit être posé sur un porte mouvement correspondant et bien ajusté.

Outillage

Posage aiguilles	502 120 5023
Clé de réglage	502 200 0501
Outil pour contrôler les fonctions de l'échappement	506 0002
Estrapades No. 6	502 150 0009
Set de roulement à billes	502 S03 SET

Beschreibung

Automatikwerk, Co-Axial Hemmung, Datum, COSC-Zertifikat, Omega-Unruh-System ohne Rücker.

Wichtige Punkte

Beim montieren der zwei Ankerbrücken-Schrauben ist die Reihenfolge genau zu befolgen (Siehe Seite 11).

Nach der Montage müssen die Hemmungsfunktionen mit dem dafür vorgesehen Werkzeug genau kontrolliert werden.

Datumskorrektur

Die Datumskorrektur zwischen 22 Uhr und 02 Uhr ist nicht empfohlen.

Zeigersetzen

Zum Zeigersetzen muss das Uhrwerk unbedingt auf den entsprechend adjustierten Werkhalter gesetzt werden.

Werkzeug

Werkhalter zum Zeigersetzen Schlüssel für Gangkontrolle	502 120 5023
Werkzeug zum kontrollieren der Hemmungsfunktion	502 200 0501
Federwinder No. 6	506 0002
Kugellagerset	502 150 0009
	502 S03 SET

Description

Automatic movement, Co-Axial escapement, date, COSC certified, Omega balance system without index.

Key points

The order of assembly of the two pallet bridge screws must be respected (See page 11).

After assembling, the escapement functions must be checked accurately with the corresponding tool.

Date correction

Date correction is not recommended between 22.00 and 02.00.



Fitting of hands

It is mandatory for the hand setting to place the movement on the corresponding adjusted movement holder.



Tooling

Movement holder for hand fitting	502 120 5023
Rate adjustment key	502 200 0501
Tool for checking the escapement function	506 0002
Mainspring winder No. 6	502 150 0009
Ball bearing set	502 S03 SET



Différences entre version 4 Hz et 3.5 Hz

Général	4 Hz		3.5 Hz
Alternances (A/h)	28'800		25'200
Angle de levée	30°		38°
Réserve de marche	44 h		48 h
Auto démarrage après actionnement du levier stop	Moyen		Bon
Roue des secondes 30.027.3	96 dents		105 dents
Roue intermédiaire 30.039	8 ailes		10 ailes
Roue co-axiale 30.040	Ø pignon = 1.999 mm		Ø pignon = 2.119 mm
Ancre	Ancienne forme 	Nouvelle forme 	Nouvelle forme 
Balancier			
Inertie	7.2 (mgcm ²)		9.4 (mgcm ²)
Diamètre	8.54 mm		8.70 mm
Épaisseur de la serge du balancier	0.37 mm		0.45 mm
Pivots	0.08 mm cylindrique		0.07 mm cône
Incabloc	0.09 mm = Ø trou du pivot		0.08 mm = Ø trou du pivot
Pouvoir correcteur pour 1 tour de vis (sur les deux vis)	57 secondes		86 secondes

Unterschiede zwischen Versionen 4 Hz und 3.5 Hz



Generell	4 Hz		3.5 Hz
Halbschwingungen (A/h)	28'800		25'200
Hebungswinkel	30°		38°
Gangreserve	44 h		48 h
Selbststart nach Betätigung des Stopphebels	Durchschnittlich		Gut
Sekundenrad 30.027.3	96 Zähne		105 Zähne
Zwischenrad 30.039	8 Flügel		10 Flügel
Koaxiales Rad 30.040	Ø Trieb = 1.999 mm		Ø Trieb = 2.119 mm
Anker	Alte Form 	Neue Form 	Neue Form 
Unruh			
Trägheitsmoment	7.2 (mgcm ²)		9.4 (mgcm ²)
Durchmesser	8.54 mm		8.70 mm
Dicke des Unruhreif	0.37 mm		0.45 mm
Zapfen	0.08 mm Zylindrisch		0.07 mm Konisch
Incabloc	0.09 mm = Ø Zapfenloch		0.08 mm = Ø Zapfenloch
Gangkorrektur bei 1 Schraubenumdrehung (Auf beiden Schrauben)	57 Sekunden		86 Sekunden

Modifications 4 Hz vs. 3.5 Hz

General	4 Hz		3.5 Hz
Vibration (A/h)	28'800		25'200
Angle of lift	30°		38°
Power reserve	44 h		48 h
Self-starting abilities after use of stop lever	Mediocre		Good
Second wheel 30.027.3	96 teeth		105 teeth
Intermediate wheel 30.039	8 leaves		10 leaves
Co-Axial wheel 30.040	Ø pinion = 1.999 mm		Ø pinion = 2.119 mm
Lever	Old shape 	New shape 	New shape 
Balance			
Inertia	7.2 (mgcm ²)		9.4 (mgcm ²)
Diameter	8.54 mm		8.70 mm
Thickness of balance rim	0.37 mm		0.45 mm
Pivots	0.08 mm cylindric		0.07 mm conical
Incabloc	0.09 mm = Ø pivot hole		0.08 mm = Ø pivot hole
Rate correction with 1 screw-revolution (On both screws)	57 sec.		86 sec.

Liste des fournitures par ordre d'assemblage
Bestandteilliste in Montager Reihenfolge
Parts listed in order of assembly

- | | |
|---------------|----------------|
| 1 = 31.120 | 9 = 31.083 |
| 2 = 31.121.1 | 10 = 31.041 |
| 3 = 51.010.21 | 11 = 31.100 |
| 4 = 53.022 | 12 = 31.101 |
| 5 = 51.080.06 | 13 = 53.200 |
| 6 = 51.050 | 14 = 10.062 |
| 7 = 51.091 | 15 = 3503 (1x) |
| 8 = 3503 (1x) | |

- | | | |
|---|---|------------------------|
|  | Très faible lubrification
Sehr kleine Menge
Very little lubrication | Moebius HP-1300 |
|  | Huile épaisse
Dickflüssiges Öl
Thick oil | Moebius HP-1300 |
|  | Graisse
Fett
Grease | Moebius 9504 |

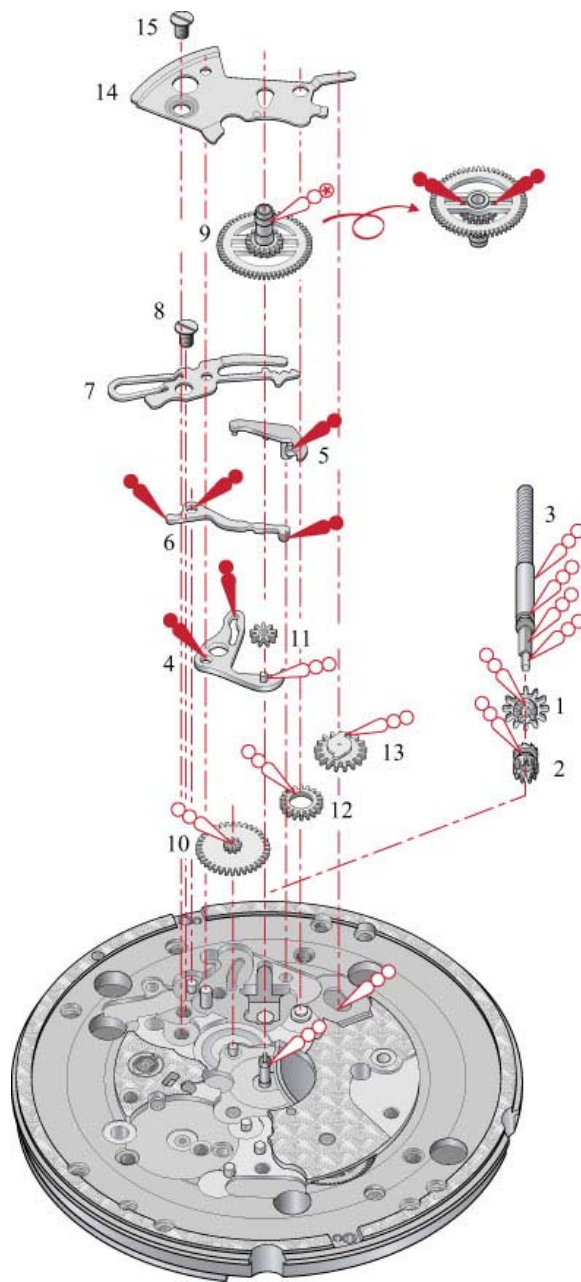

Liste des fournitures par ordre d'assemblage
Bestandteilliste in Montager Reihenfolge
Parts listed in order of assembly



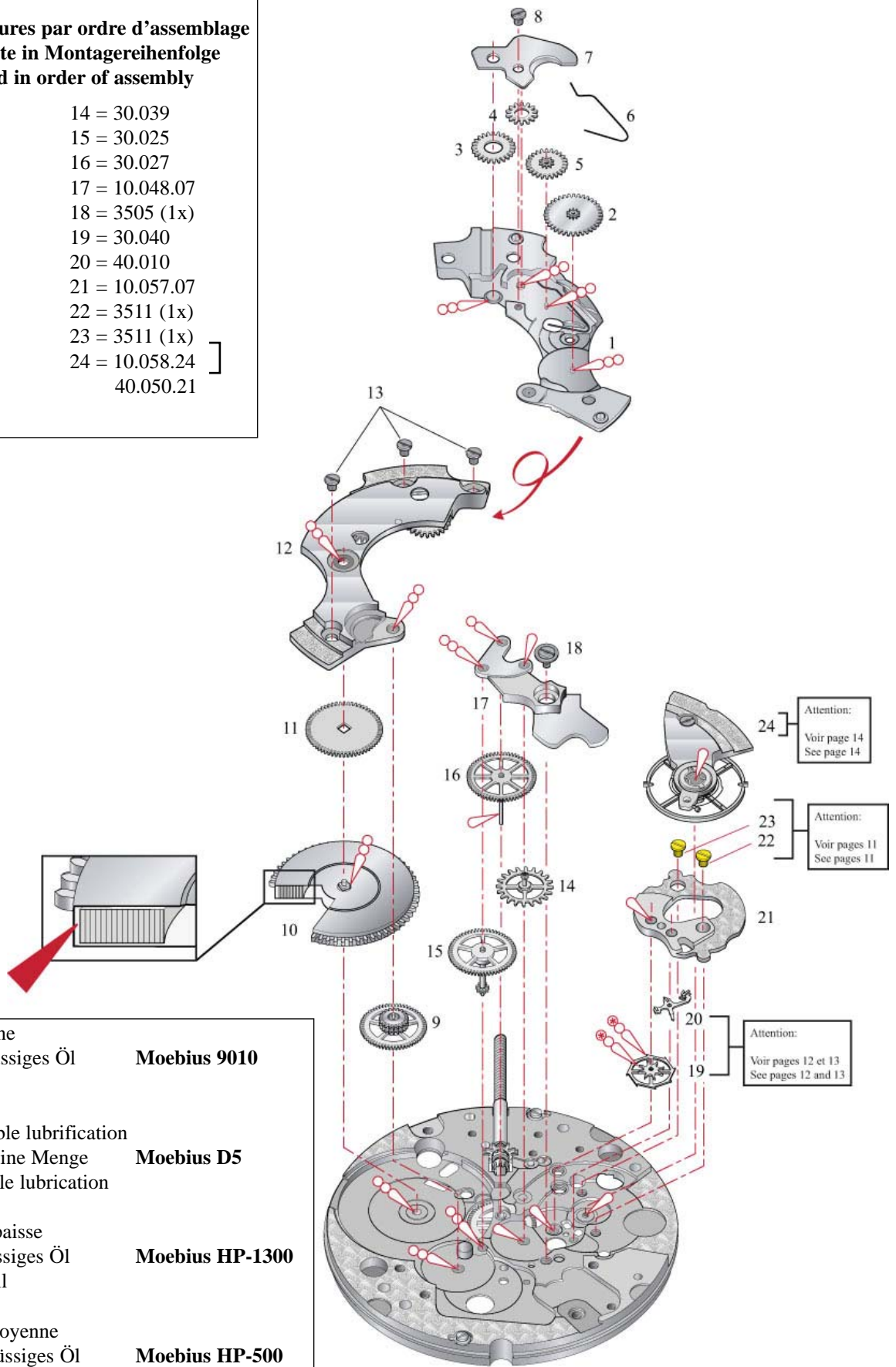

1 = 10.041.07	14 = 30.039
2 = 32.033	15 = 30.025
3 = 31.023	16 = 30.027
4 = 31.024	17 = 10.048.07
5 = 31.021	18 = 3505 (1x)
6 = 51.120	19 = 30.040
7 = 81.036	20 = 40.010
8 = 3509 (1x)	21 = 10.057.07
9 = 30.012	22 = 3511 (1x)
10 = 20.010	23 = 3511 (1x)
11 = 31.020	24 = 10.058.24
12 = 10.041.07	40.050.21
13 = 3503 (3x)	





	Huile fine Dünnflüssiges Öl Fine oil	Moebius 9010
	Très faible lubrification Sehr kleine Menge Very little lubrication	Moebius D5
	Huile épaisse Dickflüssiges Öl Thick oil	Moebius HP-1300
	Huile moyenne Mittelflüssiges Öl Medium oil	Moebius HP-500
	Graisse Fett Grease	Kluber P125

Liste des fournitures par ordre d'assemblage
Bestandteilliste in Montager Reihenfolge
Parts listed in order of assembly

1 = 56.070	8 = 3504 (1x)
2 = 12.030.07	9 = 22.010.06
3 = 32.032	10 = 3507 (3x)
4 = 32.031	11 = 3503 (3x)
5 = 32.037	12 = 52.041
6 = 52.040	13 = 12.124
7 = 12.051.07	14 = 3506 (1x)

 Très faible lubrification
 Sehr kleine Menge **Moebius 9010**
 Very little lubrication
 Huile épaisse
 Dickflüssiges Öl **Moebius D5**
 Thick oil

 Voir CS-Info No. 26
 Siehe CS-Info Nr. 26 **Lubeta V105**
 See CS-Info No. 26

Veuillez ne pas utiliser **Moebius 9010** si **Lubeta V105** est disponible.

Wenn **Lubeta V105** voranden ist, benutzen Sie nicht **Moebius 9010**.

When **Lubeta V105** is available do not use **Moebius 9010**.

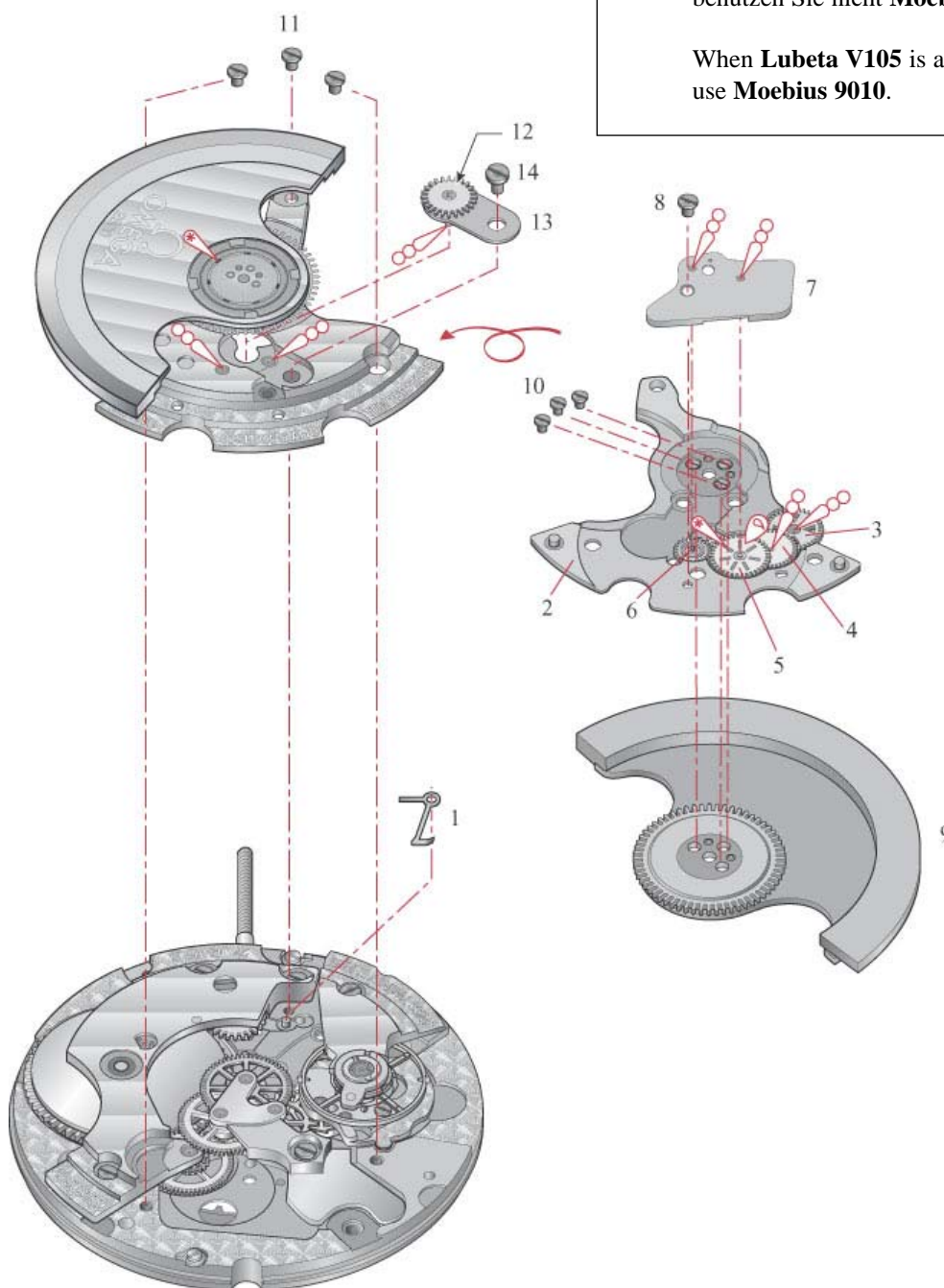

Liste des fournitures par ordre d'assemblage
Bestandteilliste in Montagerihenfolge
Parts listed in order of assembly

- | | |
|------------|---------------|
| 1 = 33.020 | 6 = 3503 (1x) |
| 2 = 91.440 | 7 = 53.251 |
| 3 = 33.011 | 8 = 3508 (1x) |
| 4 = 53.080 | 9 = 31.046.06 |
| 5 = 13.111 | |

 Huile épaisse
 Dickflüssiges Öl **Moebius D5**
 Thick oil

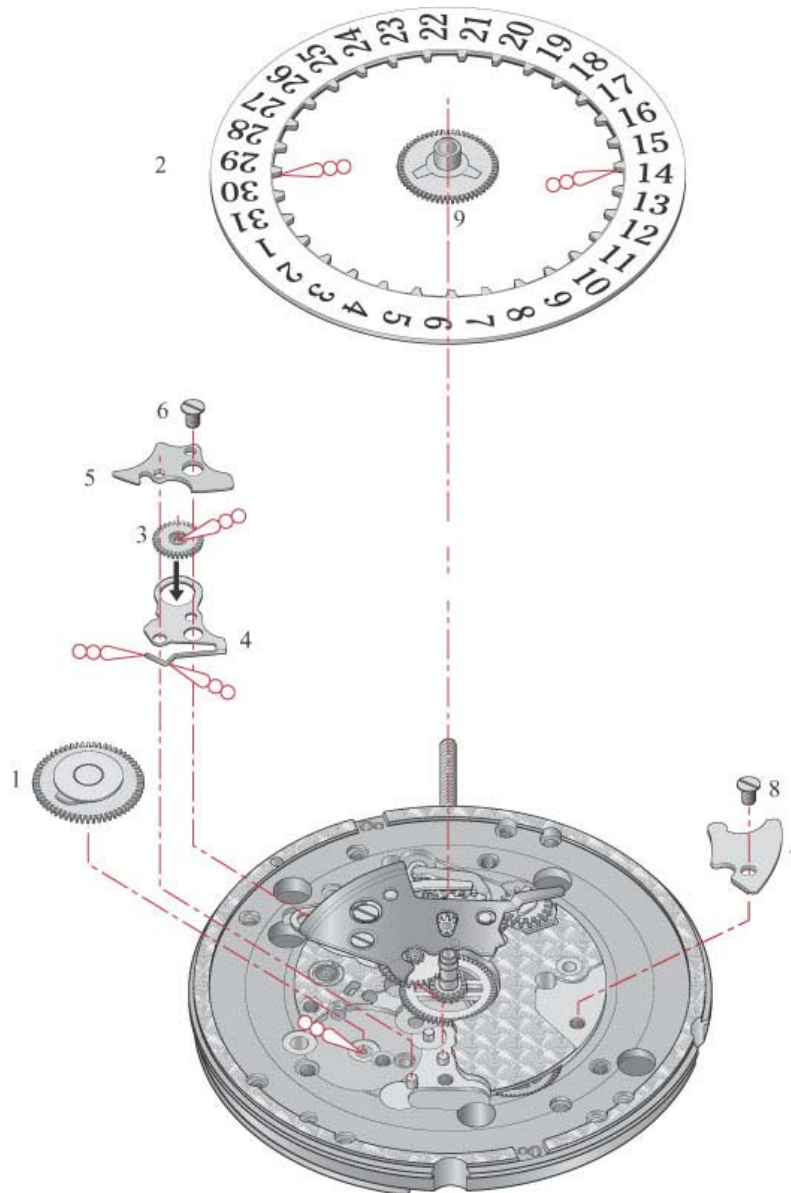

1.0 Montage

1.1 Mise en place du système d'échappement

Le pont d'ancre tient en place la roue co-axial ainsi que l'ancre. Afin d'assurer le fonctionnement de l'échappement, l'ordre d'assemblage suivant doit être respecté:

1. Monter la roue co-axial.
2. Monter l'ancre.
3. Poser le pont d'ancre et contrôler que les pivots respectifs se trouvent bien dans les logements.
4. Pour positionner le pont d'ancre la vis (4) doit être vissée en premier.
5. La deuxième vis (5) assure la bonne tenue du pont.

1.0 Zusammenbau

1.1 Zusammenbau des Hemmungssystems

Das co-axial Rad und der Anker werden durch die Ankerbrücke positioniert. Um das Funktionieren der Hemmung zu garantieren, muss folgende Montage-Reihenfolge respektiert werden:

1. Das co-axial Rad einsetzen.
2. Anker einsetzen.
3. Ankerbrücke montieren und kontrollieren, ob sich die Zapfen in den jeweiligen Lagerungen befinden.
4. Um die Ankerbrücke zu positionieren, muss die Schraube (4) zuerst eingeschraubt werden.
5. Die zweite Schraube (5) sichert den Halt der Brücke.

1.0 Assembly

1.1 Assembling of the escapement system

The pallet bridge positions the co-axial wheel and the pallet fork. To ensure the functioning of the escapement it is necessary to respect the following order of assembly:

1. Position the co-axial wheel.
2. Position the pallet fork.
3. Position the pallet bridge and check if the pivots are correctly placed in their beds.
4. To position the pallet bridge, the screw (4) must be screwed in first.
5. The second screw (5) fixes the bridge.

Fig.1.1

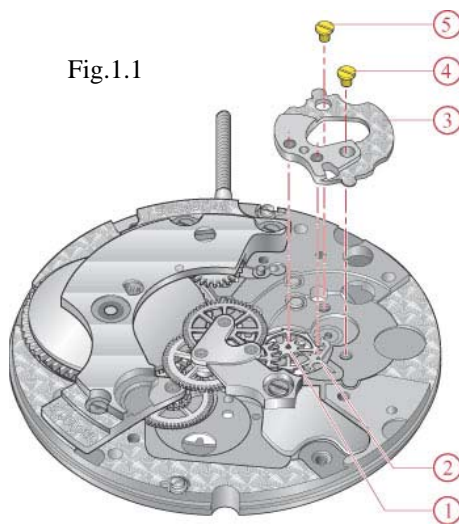

2.0 Lubrification de l'échappement

La lubrification de l'échappement est à contrôler sous un microscope. Nous recommandons également de lubrifier l'échappement directement sous le microscope.

Roue d'échappement:

Déposer une très petite goutte de D5 sur la pointe d'une dent et ensuite faire avancer l'échappement d'une dent. **Répéter cette opération 8x** afin que toutes les dents soient lubrifiées.

Fig. 2.0

2.0 Schmierung der Hemmung

Die Schmierung der Hemmung muss mit einem Mikroskop kontrolliert werden. Wir empfehlen, die Schmierung der Hemmung direkt unter dem Mikroskop vorzunehmen.

Hemmungsräd:

Ein sehr kleiner Tropfen D5 auf eine Zahnspitze geben und danach die Hemmung einen Zahn weiterlaufen lassen. Diesen **Vorgang 8x wiederholen**, bis alle Zähne geschmiert sind.

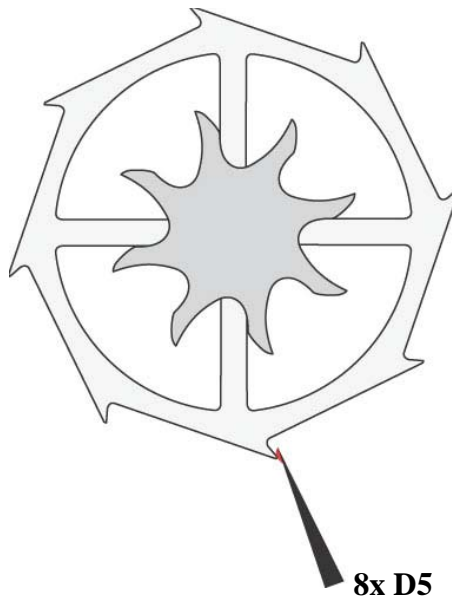

2.0 Lubrication of the escapement

The escapement lubrication must be checked with a microscope. We recommend lubricating the escapement directly under the microscope.

Escape wheel:

Put a very small drop of D5 on the tip of one tooth and then move the escapement on one tooth forward. **Repeat this procedure 8x** in order that all teeth are lubricated.

Quantité:

les tolérances de la quantité de lubrifiant sont montrées ci-dessous.

Quantität:

Die Toleranzen für die Schmierungs-Quantitäten sind auf untenstehendem Bild ersichtlich.

Quantity:

The tolerances for the lubrication quantities are shown on below picture.

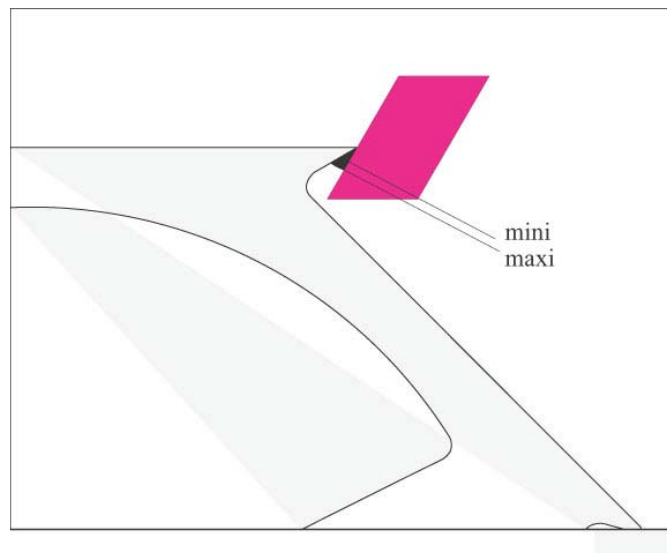

Pignon:

Déposer une très petite goutte de D5 sur les pointes de deux dents du pignon. Après la pose de la première goutte, avancer l'échappement de 3 ou 4 dents.

Trieb:

Ein sehr kleiner Tropfen D5 auf zwei Triebflügelspitzen geben. Vor der Abgabe des zweiten Tropfens, die Hemmung 3-4 Zähne weiterlaufen lassen.

Pinion:

Put a very small drop of D5 on the tip of two teeth of the pinion. Move the escapement 3-4 teeth after having placed the first drop.

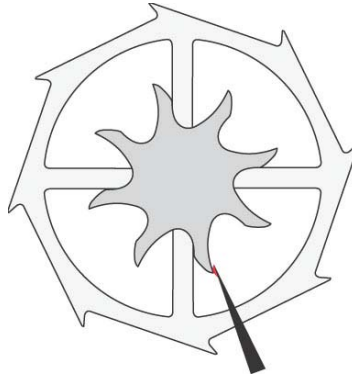

2x D5

Quantité:

Sur la photo ci-dessous, la quantité requise de lubrifiant est indiquée.

Quantität:

Auf untenstehendem Photo ist die benötigte Quantität D5 zu sehen.

Quantity:

On below picture the required quantity of lubricant is shown.

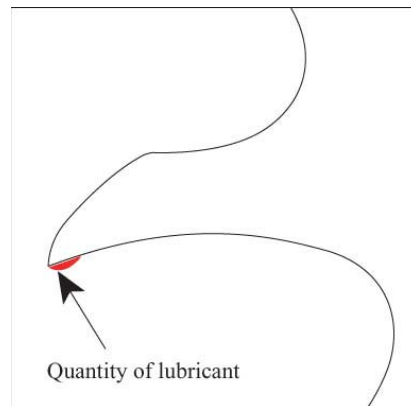
**Important:**

Il ne doit pas ya avoir de lubrifiant dans l'engrenage entre la dent et le pignon (voir cercle ci-dessous).

Wichtig:

Es darf auf keinen Fall Schmierung zwischen Zahn und Triebflügel (Siehe untenstehender Kreis) gelangen.

Important:

There must be no lubricant between thooth and pinion (see circle below).

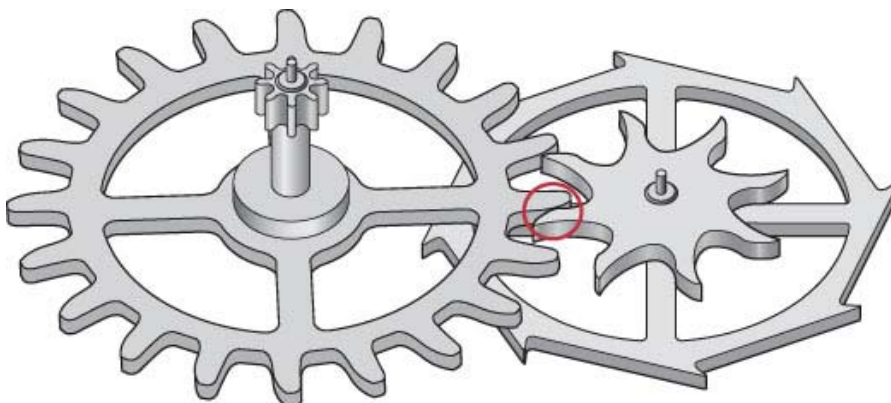

3.0 Mise en place du pont de balancier

Comme le plateau du balancier se trouve sous la fourchette de l'ancre, le balancier doit être monté délicatement.

1. Mettre le pont de balancier avec le balancier en place, le pont en direction du centre de mouvement.
2. Contrôler que le balancier soit bien en place et que le pivot de l'axe de balancier soit dans son logement.
3. Tourner le pont délicatement dans sa position normale.
4. Bloquer la vis du pont.

3.0 Zusammenbau der Unruhbrücke

Da sich die Hebelscheibe unter der Ankergabel befindet, muss die Unruh vorsichtig montiert werden.

1. Unruhbrücke komplett mit Unruh setzen. Die Brücke zeigt in Richtung Zentrum des Werks.
2. Kontrollieren ob die Unruh gut positioniert ist und ob sich der Zapfen der Unruhachse in der Lagerung befindet.
3. Die Brücke vorsichtig in die normale Position drehen.
4. Brücke mit der Schraube befestigen.

3.0 Assembling of the balance bridge

As the table roller is under the pallet fork, the balance must be assembled carefully.

1. Position the complete balance bridge (with balance). The bridge is pointing towards the center of the movement.
2. Check the position of the balance. The pivot of the balance-staff must be correctly placed in its bed.
3. Carefully turn the bridge to its normal position.
4. Fix the bridge with its screw.

Fig. 3.0

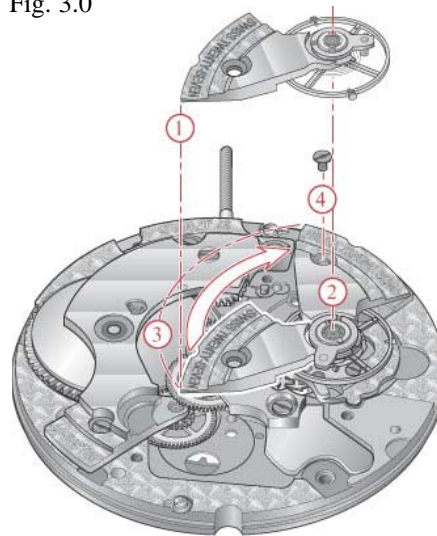

3.1 Démontage du pont de balancier

Le retrait du pont du balancier se fait dans le sens inverse de la procédure 3.3. Pour ne pas endommager le balancier lors du démontage, le pont doit être tourné en direction du centre de mouvement. Dans cette position le pont peut être retiré sans risque.

3.1 Demontieren der Unruhbrücke

Um die Unruhbrücke zu demontieren, müssen die Teile in umgekehrter Reihenfolge (3.3) entfernt werden. Um die Unruh nicht zu beschädigen, muss die Brücke zuerst in Richtung Zentrum des Werks gedreht werden. In dieser Position kann die Brücke ohne Risiko demontiert werden.

3.1 Disassembling of the balance bridge

The balance bridge must be disassembled by removing the parts in the opposite order of procedure 3.3. To avoid any risk of damaging the balance, the bridge has to be turned towards the center of the movement. In this position the bridge may be disassembled without any risk.

Fig. 3.1

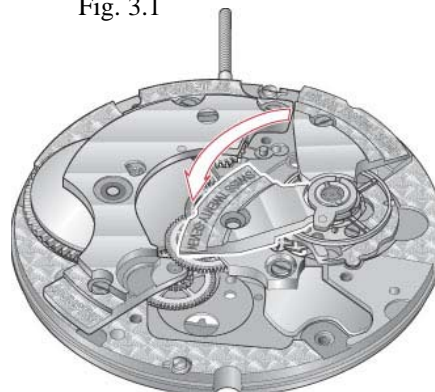

4.0 Réglage et contrôles

4.1 Balancier

Le balancier annulaire porte deux micro-vis réglantes. Un écart de retard est ajusté par vissage des micro-vis (en direction du centre du balancier) ce qui diminue son moment d'inertie et donne de l'avance. Un écart d'avance est ajusté par dévissage des micro-vis (en direction opposée au centre du balancier). Cela augmente son moment d'inertie et donne du retard.

Les avantages du système avec les micro-vis sont les suivants:

- Meilleur isochronisme puisqu'il n'y a pas d'effet perturbateur des goupilles de raquette avec le spiral.
- Avec les micro-vis réglantes, des corrections de marche extrêmement précises peuvent être effectuées.

La correction se fait toujours sur les deux vis réglantes afin d'éviter un balourd du balancier

4.0 Regulierung und Kontrolle

4.1 Unruh

Auf dem Unruhreif befinden sich zwei Regulierschrauben. Ein Nachgehen der Uhr kann durch Einschrauben (Richtung Unruhzentrum) korrigiert werden. Durch das Einschrauben wird das Trägheitsmoment reduziert und eine schnellere Schwingung erzielt. Ein Vorgehen der Uhr wird durch Heraus-schrauben (Entgegen dem Unruh-zentrum) der Schrauben korrigiert.

Die Vorteile des Systems mit Regulier-schrauben sind die folgenden:

- Verbessertes Isochronismus, da kein störender Kontakt der Spirale mit den Ruckerstiften.
- Der tägliche Gang kann durch die Regulierschrauben hochpräzise ajus-tiert werden.

Um eine Unwucht zu verhindern, muss die Regulierung immer mit beiden Schrauben durchgeführt werden.

4.0 Adjustments and tests

4.1 Balance

The annular balance carries two regu-lating screws. If the watch is running slow it can be adjusted by screwing in both screws (towards the balance center). Screwing in reduces the moment of inertia which results in a faster rate. If the watch is running fast it can be adjusted by unscrewing the screws (away from the balance center).

The advantages of a timing system with regulating screws are the following:

- Improved isochronism as there are no disturbing contacts between regulating pins and hairspring.
- Due to the regulating screws, the daily rate can be adjusted extremely accurate.

To avoid an imbalance, the adjust-ments must always be made with both screws.

Fig. 4.1

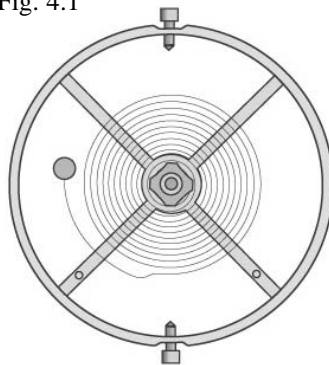

5.0 Contrôle de marche

L'amplitude de la version Co-Axial 3.5 Hz ne peut pas être mesurée correctement sur un appareil conventionnel. Il faut alors utiliser les nouveaux appareils Witschi, le **Watch Expert II** ou la nouvelle version du **Chronoscope M1**.

L'angle de levée doit être réglé à **38 degrés**.

5.1 Clé de réglage

Afin d'ajuster la marche même avec le mouvement emboîté, un outil de correction a été développé. En tournant les deux vis du balancier d'un tour complet, la marche sera corrigée de 86 secondes. Sur l'extérieure de l'outil se trouve une graduation. Une division correspond à une correction de la marche d'environ 1.5 seconde.

Une des vis se trouve entre deux bras du balancier qui sont spécialement marqués par des points (voir figure 4.1) afin de pouvoir identifier facilement chacune des deux vis pendant la procédure de correction.

Fig. 5.0

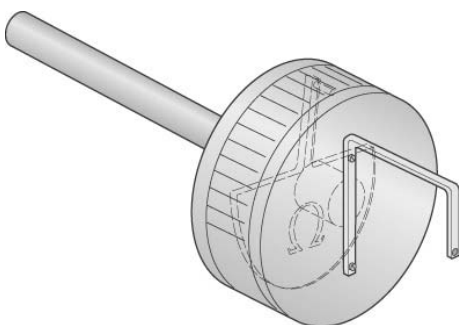

REF. 502 200 0501

Important:

La correction de la marche se fait toujours **sur les deux vis réglantes** afin d'éviter un balourd du balancier

5.0 Gangkontrolle

Auf herkömmlichen Messgeräten kann die Amplitude der Co-Axial version 3.5 Hz nicht korrekt gemessen werden. Es sind dafür die neuen Witschi Geräte **Watch Expert II** oder die neuste version **Chronoscope M1** zu verwenden.

Der Hebungswinkel muss auf **38 Grad** eingestellt werden.

5.1 Regulierungsschlüssel

Um den Gang mit eingeschalteter Werk regulieren zu können, wurde ein spezielles Korrekturwerkzeug entwickelt. Bei einer kompletten Drehung beider Schrauben der Unruh, wird der Gang um 86 Sekunden korrigiert. Auf dem Umgang des Werkzeugs befindet sich eine Skala. Eine Einheit bedeutet eine Korrektur des Ganges von ca. 1.5 Sekunde.

Eine der beiden Schrauben befindet sich zwischen zwei Armen des Unruhreif, welche mit Punkten versehen sind (siehe Fig. 4.1). Diese Punkte ermöglichen ein Erkennen der Schrauben während des Vorganges.

Fig. 5.1

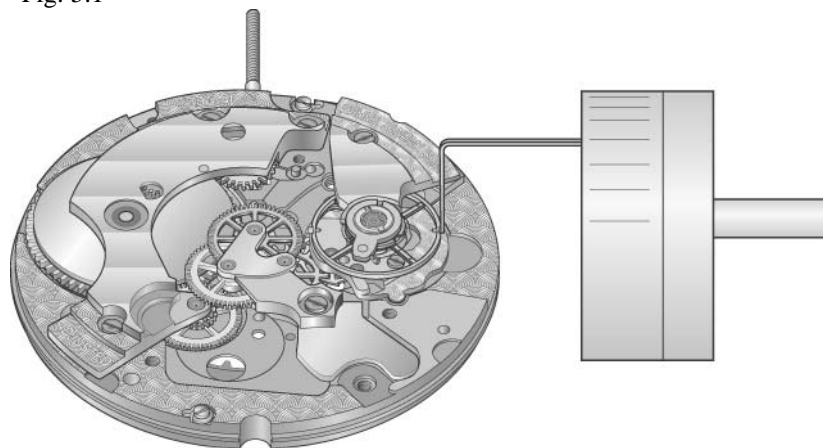

Wichtig:

Um eine Unwucht zu verhindern, muss die Regulierung **immer mit beiden Schrauben** durchgeführt werden.

5.0 Checking the rate

The amplitude of the 3.5 Hz Co-Axial version cannot be measured accurately on conventional measuring devices. Thus, the new **Witschi Expert II** or the latest version of **Chronoscope M1** must be used.

The angle of lift has to be set to **38 degrees**.

5.1 Adjustment key











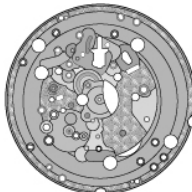





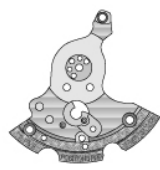





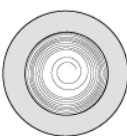









































To adjust the rate on an encased movement, a special correction tool has been developed. One complete revolution of both regulating screws of the balance represents a rate correction of 86 seconds. The correction can be read on the scale of the circumference of the tool. One division of the scale represents a rate correction of approximately 1.5 second.

One of the regulating screws is between two arms of the annular balance which are marked with dots (see fig. 4.1) making it easy to distinguish one screw from the other during the correction.

Important:

To avoid an imbalance, the adjustments must always be made **with both screws**.

Liste des fournitures - Bestandteile - Spare parts list

									3503				
10.020.07	10.041.07	10.048.07	10.057.07	10.058.24	10.062	10.300	12.030.07	12.051.07					
									3505				
12.124	13.111	20.010	20.030	20.060	20.102	22.010.06	22.040	22.042	3511				
											3504		
30.012	30.025	30.0273	30.039	30.040	31.020	31.021	31.023	31.024	31.041	31.046.063			
													3506
31.0833	31.100	31.101	31.120	31.121.1	32.031	32.032	32.033	32.037	33.011	33.020	40.010	40.050.21	3507
												3512	
40.200	51.010.21	51.050	51.080.06	51.091	51.120	52.040	52.041	53.022	53.080	53.200	53.251		
												3508	
56.070	70.530	70.531	70.640	70.641	70.900	70.901	78.004	78.005	80.400	81.036	91.440*	3509	
												3510	

Cal.	No. CS	Désignation	Bezeichnung	Designation
2500C	10.020.07	Platine	Werkplatte	Main plate
2500B	10.041.07	Pont de barillet	Federhausbrücke	Barrel bridge
2500B	10.048.07	Pont de rouage	Räderwerkbrücke	Wheel train bridge
2500	10.057.07	Pont d'ancre	Ankerbrücke	Pallet bridge
2500B	10.058.24	Pont de balancier	Unruhbrücke	Balance bridge
1120	10.062	Pont de rouage de minuterie	Wechselradbrücke	Minute train bridge
1120	10.300	Fixateur de cadran	Zifferblatthalter	Dial fastener
2500B	12.030.07	Bâti du dispositif automatique	Automatik brücke, mit Steinen	Automatic bridge
1120	12.051.07	Pont inférieur du dispositif automatique	Untere Brücke für Automatik	Automatic device lower bridge
1120	12.124	Plaquette de maintien de l'inverseur	Halteplatte für Wechsler	Reverser maintaining plate
1120	13.111	Plaque de maintien du sautoir de quantième	Halteplatte für Datumraste	Date jumper maintaining plate
2500C	20.010	Barillet complet	Federhaus komplett	Barrel complete

Cal.	No. CS	Désignation	Bezeichnung	Designation
1120	20.030	Tambour et couvercle de barillet	Federhaustrommel und Deckel	Barrel drum and cover
1120	20.060	Arbre de barillet	Federwelle	Barrel arbor
2500C	20.102	Ressort	Schleppfeder	Mainspring
2500	22.010.06	Masse oscillante complète	Schwungmasse komplett	Oscillating weight complete
1120	22.040	Roulement à billes	Kugellager	Ball bearing
1120	22.042	Verrou de masse oscillante	Riegel für Schwungmasse	Oscillating weight bolt
1120	30.012	Roue intermédiaire	Zwischenrad	Intermediate wheel
1120	30.025	Roue moyenne	Kleinbodenrad	Third wheel
2500C	30.0273	Roue de seconde H3	Sekundenrad	Second wheel
2500C	30.039	Roue intermédiaire d'échappement	Zwischen-Hemmungsrad	Intermediate escape wheel
2500C	30.040	Roue co-axial	co-axial Rad	co-axial wheel
1120	31.020	Rochet	Sperrad	Ratchet wheel
1120	31.021	Rochet intermédiaire	Zwischensperrad	Intermediate ratchet wheel
1120	31.023	Roue de couronne	Kronrad	Crown wheel
1120	31.024	Roue de couronne intermédiaire	Zwischen-Kronrad	Intermediate crown wheel
1120	31.041	Roue de minuterie	Wechselrad	Minute wheel
1120	31.046.063	Roue des heures, H3	Stundenrad	Hour wheel
1120	31.0833	Chaussée, H3	Minutenrohr	Cannon pinion
1120	31.100	Renvoi	Zeigerstellrad	Setting wheel
1120	31.101	Renvoi intermédiaire	Zwischen-Zeigerstellrad	Intermediate setting wheel
1120	31.120	Pignon de remontoir	Aufzutrieb	Winding pinion
1120	31.121.1	Pignon coulant	Kupplungstrieb	Sliding pinion
1120	32.031	Roue de réduction	Reduktionsrad	Reduction wheel
1120	32.032	Roue intermédiaire de réduction	Zwischen-Reduktionsrad	Intermediate reduction wheel
1120	32.033	Roue entraîneuse de rochet	Mitnehmerrad für Sperrad	Ratchet wheel driving wheel
1120	32.037	Roue d'inversion	Umkehrad	Reversing wheel
1120	33.011	Roue intermédiaire de quantième	Datum-Zwischenrad	Intermediate date wheel
1120	33.020	Roue entraîneuse de l'indicateur de quantième	Datumanzeiger-Mitnehmerrad	Date indicator driving wheel
2500C	40.010	Ancre	Anker	Pallet fork
2500C	40.050.21	Balancier complet	Unruh komplett	Balance complete
2500B	40.200	Porte-piton	Spiralklötzchenträger	Stud support
1120	51.010.21	Tige de remontoir, diamètre de filetage 0,90 mm	Aufzugwelle, Gewindedurchmesser 0,90 mm	Winding stem, thread diameter 0,90 mm
1120	51.050	Bascule de pignon coulant	Kupplungstriebhebel	Yoke
1120	51.080.06	Tirette	Winkelhebel	Setting lever
1120	51.091	Sautoir de tirette	Winkelhebelraste	Setting lever jumper
1120	51.120	Cliquet	Klinke	Click
1120	52.040	Inverseur	Wechsler	Reverser
1120	52.041	Inverseur auxiliaire	Hilfswechsler	Auxiliary reverser
1120	53.022	Commande du correcteur de quantième	Schalthebel für Datumkorrektor	Date corrector operating lever
1120	53.080	Sautoir de quantième	Datumraste	Date jumper
1120	53.200	Correcteur de quantième	Datumkorrektor	Date corrector
1120	53.251	Plaquette supplémentaire de maintien de l'indicateur	Zusatzhalteplättchen für Anzeige	Additional indicator maintaining small plate

Cal.	No. CS	Désignation	Bezeichnung	Designation
2500C	56.070	Levier stop	Stopphebel	Stop lever
2500C	70.530	Amortisseur de balancier, dessus	Stossicherung für Unruh, oben	Shock-absorber for balance, top
2500C	70.531	Amortisseur de balancier, dessous	Stossicherung für Unruh, unten	Shock-absorber for balance, bottom
2500C	70.640	Chaton de balancier, dessus	Steinfutter, oben	In settings, upper
2500C	70.641	Chaton de balancier, dessous	Steinfutter, unten	In settings, lower
1120	70.900	Pierre contre pivot, dessus	Deckstein, oben	Cap jewels, upper
1120	70.901	Pierre contre pivot, dessous	Deckstein, unten	Cap jewels, lower
1120	78.004	Ressort-amortisseur, dessus	Incablockfeder, oben	Incabloc-spring, upper
1120	78.005	Ressort-amortisseur, dessous	Incablockfeder, unten	Incabloc-spring, lower
1120	80.400	Tube de centre	Zentrumlagerrohr	Centre tube
1120	81.036	Plaque de cliquet	Klinkenplatte	Click plate
2500	91.440*	Indicateur de quantième, pour ouverture de guichet à 3 heures	Datumanzeiger, für Fenster bei 3 Uhr	Date indicator, for window opening at 3 o'clock
1120	3503	3x Vis de pont de barillet	Schraube für Federhausbrücke	Screw for barrel bridge
1120	3503	1x Vis de pont de rouage de minuterie	Schraube für Wechselradbrücke	Screw for minute train bridge
1120	3503	3x Vis de bâti du dispositif automatique	Schraube für Gestell für Automatik	Screw for automatic device framework
1120	3503	1x Vis de plaque de maintien du sautoir de quantième	Schraube für Halteplatte für Datumraste	Screw for date jumper maintaining plate
1120	3503	1x Vis de pont de balancier	Schraube für Unruhbrücke	Screw for balance bridge
1120	3503	1x Vis de sautoir de tirette	Schraube für Winkelhebelraste	Screw for setting lever jumper
1120	3504	1x Vis de pont inférieur du dispositif automatique	Schraube für untere Brücke für Automatik	Screw for automatic device lower bridge
1120	3505	1x Vis de pont de rouage	Schraube für Räderwerkbrücke	Screw for train wheel bridge
1120	3506	1x Vis de plaquette de maintien de l'inverseur	Schraube für Halteplatte für Wechsler	Screw for reverser maintaining plate
1120	3507	3x Vis de roulement à billes	Schraube für Kugellager	Screw for ball bearing
1120	3508	1x Vis de plaquette supplémentaire de maintien de l'indicateur	Schraube für Zusatzhalteplättchen für Anzeige	Screw for additional indicator maintaining plate
1120	3509	1x Vis de plaque de cliquet	Schraube für Klinkenplatte	Screw for click plate
1120	3510	2x Vis de bride d'emboîtement	Schraube für Befestigungsplättchen	Screw for casing clamp
2500	3511	2x Vis de pont d'ancre	Schraube für Ankerbrücke	Screw for pallet bridge
2500	3512	1x Vis de piton	Schraube für Spiralklötzchen	Screw for stud

* Plusieurs versions disponibles/Verschiedene versionen erhältlich/Several versions available

Réglage – Reglage – Timing

Démagnétiser le mouvement avant les contrôles.

Das Werk ist vor allen Prüfungen zu entmagnetisieren.

Demagnetize the movement before the checks

Positions de réglages:

Kontrollpositionen:

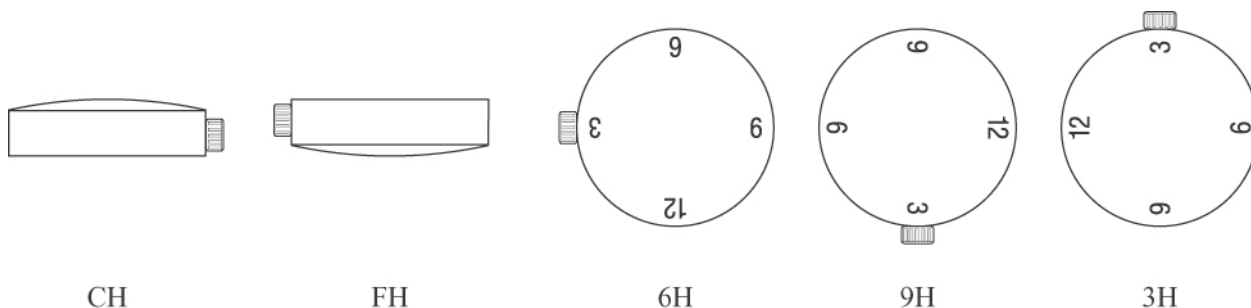

Alternances: 25'200 A/h

Halbschwingungen: 25'200 A/h

Vibrations: 25'200 A/h

Angle de levée (°) 38

Hebungswinkel (°) 38

Angle of lift (°) 38

Réserve de marche 48 heures

Gangreserve: 48 Stunden

Power reserve. 48 hours

	MM 0 h	Δ 0 h	Δ 24 h	Ampl. 24 h VB	Réserve de marche Gangreserve Power reserve
Valeurs limites Max. Werte Max. values	Pour les tolérances veuillez consulter la Working Instructions No. 5 Für die Toleranz-Werte bitte Working Instructions No. 5 konsultieren For tolerances please see Working Instructions No. 5				

MM 0 h: Marche moyenne dans les 5 positions à 0 heure. (entre 30 et 90 minutes après le remontage complet).

MM 0 h: Mittlerer Gang der 5 Positionen bei 0 Uhr. (zwischen 30 und 90 Minuten nach Vollaufzug).

MM 0 h: Average rate in the 5 positions at 0 hour. (between 30 and 90 minutes after complete winding).

Δ 0 h: La plus grande différence de marche dans les 5 positions à 0 heure (entre 30 et 90 minutes après le remontage).

Δ 0 h: Größte Gangdifferenz der 5 Positionen bei 0 Uhr (zwischen 30 und 90 Minuten nach Vollaufzug).

Δ 0 h: The biggest rate difference in the 5 positions at 0 hour (between 30 and 90 minutes after complete winding).

Δ 24 h: La plus grande différence de marche dans les 5 positions après 24 heures (entre 23 h 30 et 25 heures après le remontage complet).

Δ 24 h: Größte Gangdifferenz der 5 Positionen nach 24 Stunden (zwischen 23 30 und 25 Stunden nach Vollaufzug).

Δ 24 h: The biggest rate difference in the 5 positions after 24 hours (between 23 h 30 and 25 hours after complete winding).



Ampl. 24 h: Amplitude minimum en position verticale après 24 heures.

Ampl. 24 h: Minimale Amplitude in vertikaler Positionen nach 24 Stunden.

Ampl. 24 h: Minimum amplitude in vertical position after 24 hours.

	Guide technique / Technische Anleitung / Technical Guide		TG-19-C-003-FDE	C
	Made by: pelrom	Date: 04.04.2005		

Release of Technical Guide				
Date of first release:	07.07.2004	Version A	Made by:	Pelrom
Date of last release:	04.04.2005	Version B		

Traceability of modifications			
<i>Replacement of lubricants</i>			
	Old	New	Date:
	Moebius Microgliss D5	Moebius SYNT-HP-1300	04.04.2005
	Moebius 9501	Moebius 9504	

Introduction d'une nouvelle huile	
	Moebius SYNT-HP-500
	04.04.2005